

About the Wood and Finish

This product has been carefully crafted of: MDF, solid pine wood and/or pine veneers. These materials derive from plantations, a renewable and well managed forest, therefore, not endangering the environment. The highest quality standards have been implemented to assure a sturdy and reliable product. Due to the natural variances in the

graining of wood, you may notice subtle differences in the shading and tone of the color stain, warp, holes, wood knots and also small cracks. This is not a defect.

But rather a result of the natural beauty of the wood itself.

Care and maintenance:

Dust when needed using a smooth, dry cloth. Household furniture polish can be used occasionally to restore luster.



ASSEMBLY INSTRUCTIONS

2332 - FULL OVER DOUBLE TWIN BUNK

Thank you for purchasing this quality product. Be sure to check all packing materials carefully for small parts which may have come loose inside the carton during shipment. Separate, identify and count all parts and hardware. Compare with the parts list to be sure all parts are present.

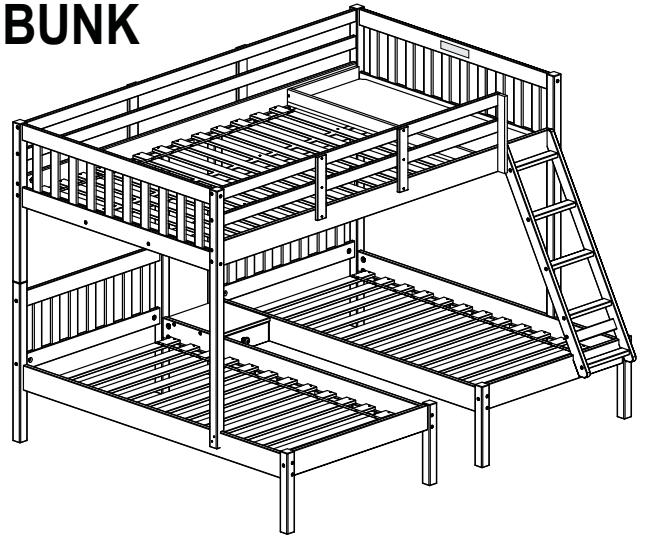

**“DO NOT TIGHTEN SCREWS
UNTIL COMPLETELY ASSEMBLED”**

SIZE OF MATTRESS AND FOUNDATION (SUPPORT)

These low beds are designed to use a twin mattress (37 1/2" - 38 1/2" x 74" - 75") and bunkie board (37 1/2" x 74"). The upper bed is designed to use a full mattress (53 1/2" - 54 1/2" x 74" - 75") and bunkie board 53 1/2" - 74". The total mattress thickness must not exceed 9".

Note: there must be at least 5" from top surface of mattress to top edge or guardrails.

REPLACEMENT PARTS.

Replacement parts, including additional guardrails, may be obtained from place of purchase or original distributor.

TO OBTAIN PARTS, PLEASE CONTACT: **DONCO TRADING COMPANY - FORT WORTH, TEXAS**

SAFETY WARNINGS!

- 1- Follow the information on the warning label appearing on the upper bunk end structure and on the carton. Do not remove warning label from bed.
- 2- Always use the recommended size mattress or mattress support, or both, to help prevent the likelihood of entrapment or falls.
- 3- Surface of mattress must be at least 5" below the upper edge of guardrails.
- 4- Do not allow children under 6 years of age to use the upper bunk.
- 5- Prohibit more than one person on upper bunk.
- 6- Periodically check and ensure that the guardrail, ladder and other components are in their proper position free from damage, and that all connectors are tight.
- 7- Do not allow horseplay on or under the bed and prohibit jumping on the bed.
- 8- Always use the ladder for entering and leaving the upper bunk.
- 9- Do not use substitute parts. Contact distributor or dealer for replacement parts.
- 10- Use of a night light may provide added safety precaution for a child using the upper bunk.
- 11- If the bunk bed will be placed next to a wall, the guardrail that runs the full length of the bed should be placed against the wall to prevent entrapment between the bed and the wall.
- 12- Always use guardrails on both long sides of the upper bunk.
- 13- The use of water or sleep flotation mattresses is prohibited.
- 14- Keep these instructions for future reference.
- 15- Strangulation Hazard - Never attach or hang items to any part of the bunk bed that are not designed for use with the bed: for example, but not limited to hooks, belts, and jump ropes, etc.

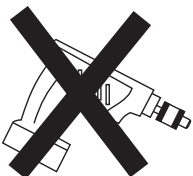

!
* Use of power tool to assemble this product will invalidate any claim and damage this product making unsafe !!!
* Please assemble on a clean soft surface to avoid damage.

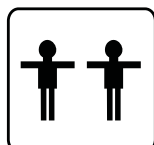

+



Tools Required

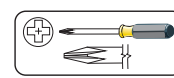

(Not included)

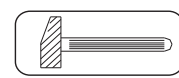

(Not included)



IMPORTANT: PLEASE READ INSTRUCTIONS BEFORE STARTING THE ASSEMBLY

Part list: - 2332 - Full Over Double Twin Bunk

WARNING LABEL

CERTIFICATION LABEL

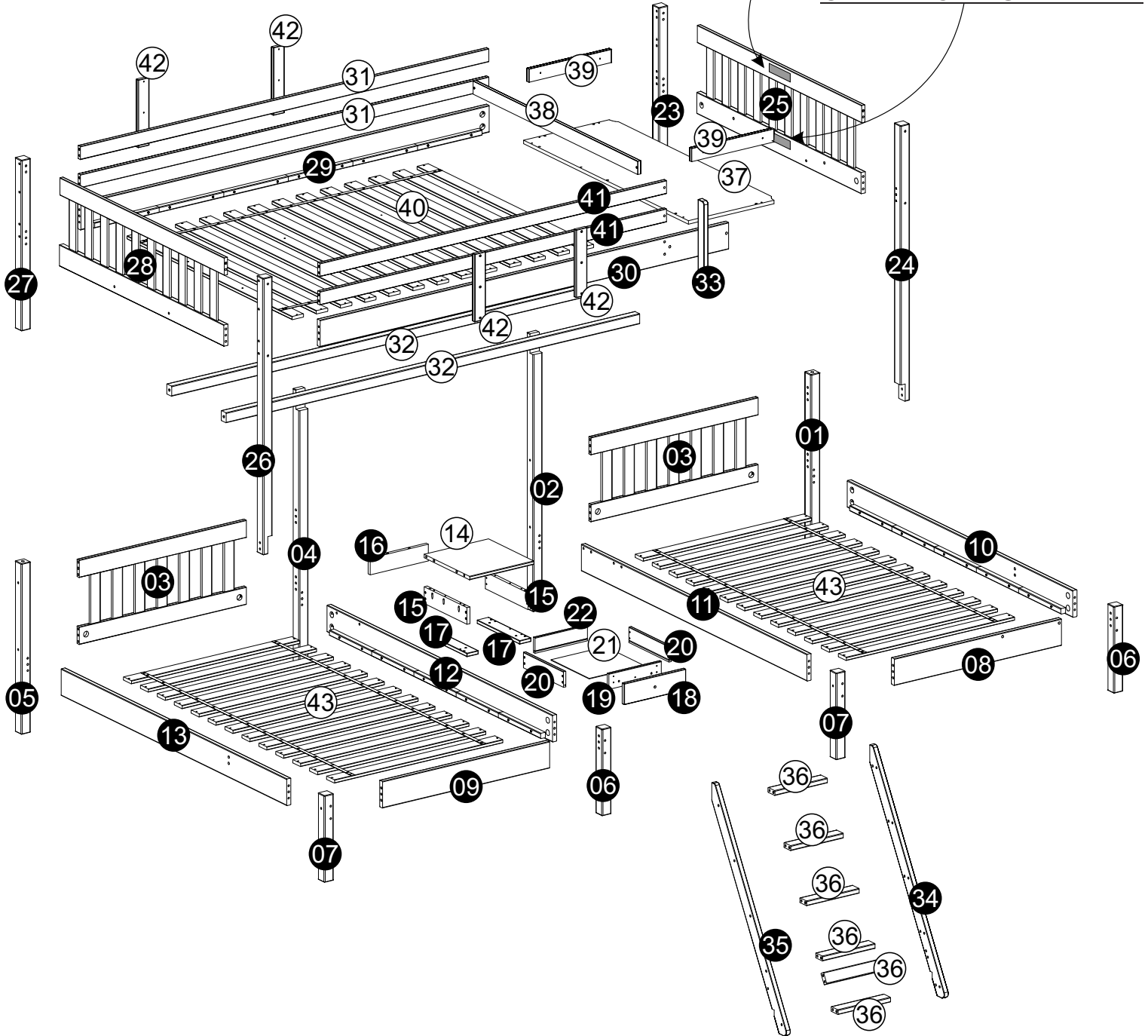

CAUTION!

Please be careful when assembling this product due the parts are extremely heavy. Also, please do not allow kids around when assembling this bed to avoid injuries!

Identifying the Hardware-Identify the hardware using the illustrations below.

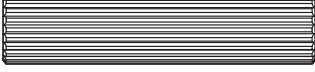
A  Qty **87**
1 5/16" Wood Dowel

B  Qty **04**
1" Wood Dowel

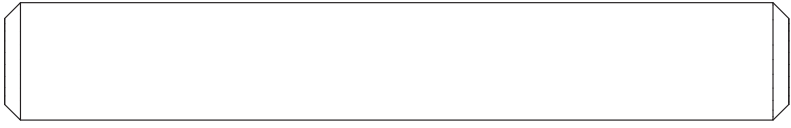
C  Qty **02**
3 15/16" Wood Dowel

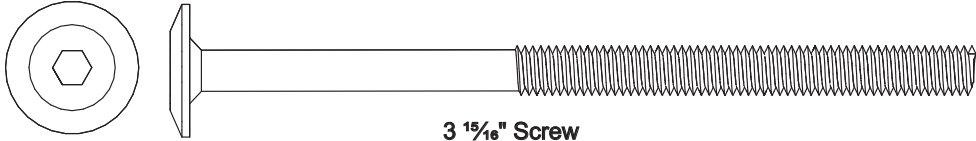
D  Qty **36**
3 15/16" Screw

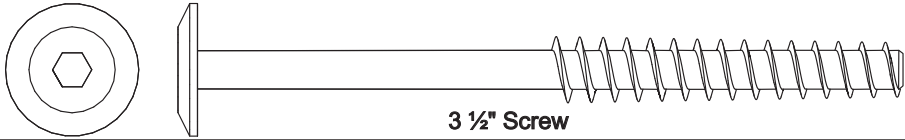
E  Qty **14**
3 1/2" Screw

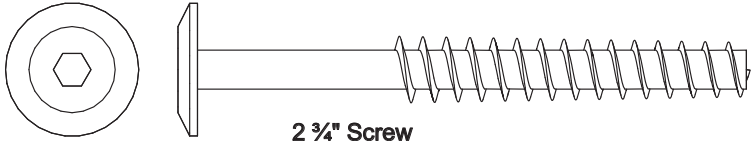
F  Qty **04**
2 3/4" Screw

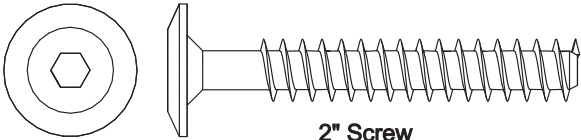
G  Qty **26**
2" Screw

H  Qty **36**
1/4" Half Moon

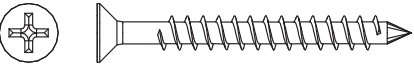
I  Qty **21**
1 5/16" Screw

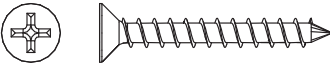
J  Qty **122**
1 3/16" Screw

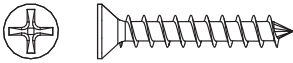
K  Qty **04**
1" Screw

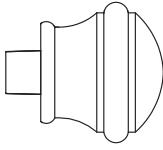
L  Qty **01**
Knob

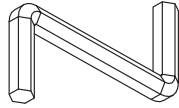
M  Qty **02**
Hex Screwdriver

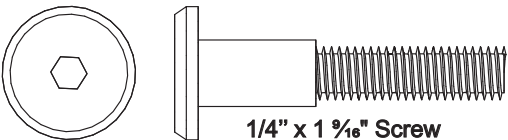
N  Qty **04**
1/4" x 1 5/16" Screw

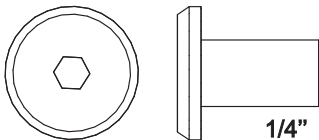
O  Qty **04**
1/4"

01

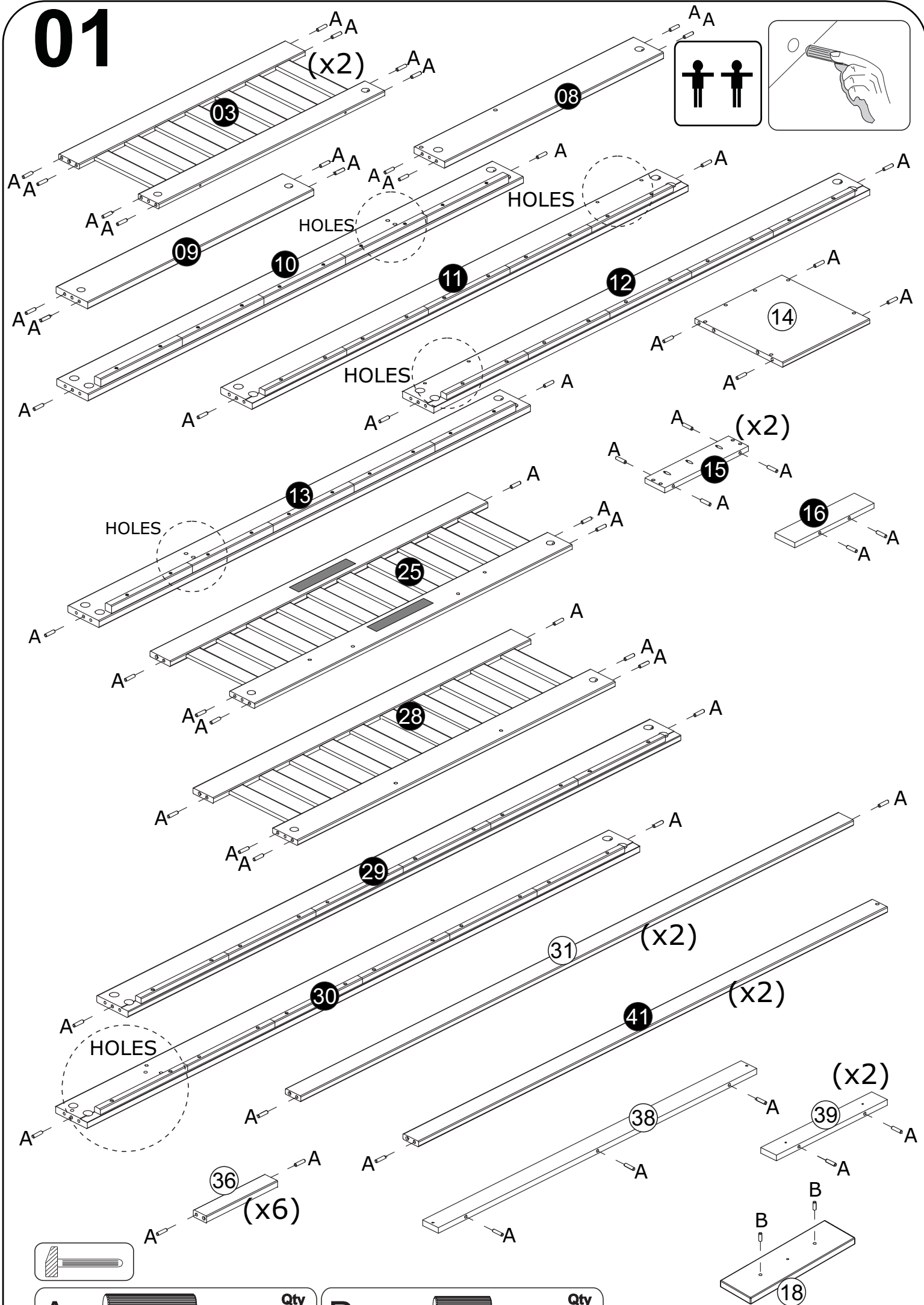

A



1 5/16" Wood Dowel

Qty
87

B



1" Wood Dowel

Qty
02

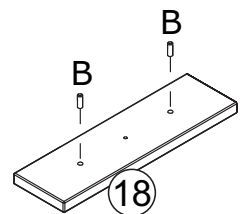

02

RIGHT BOTTOM BED

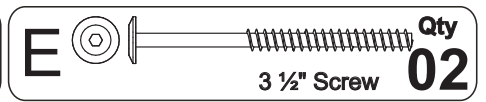
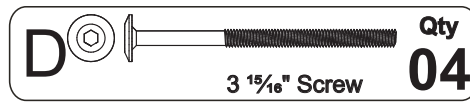
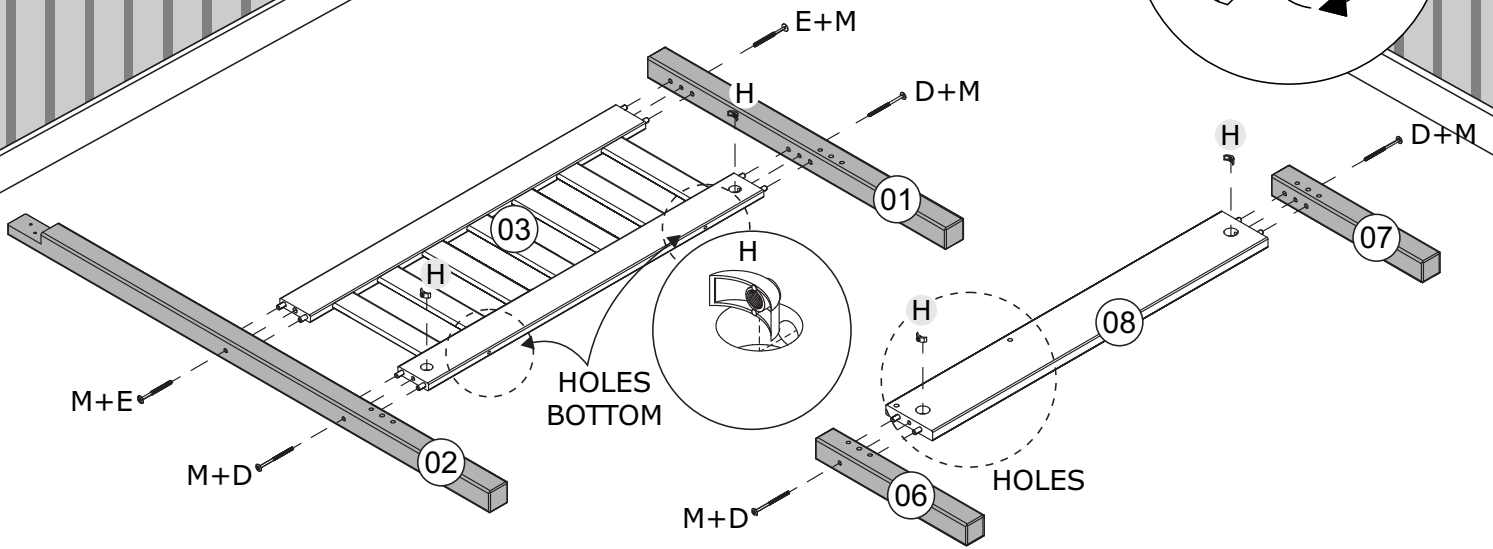

03

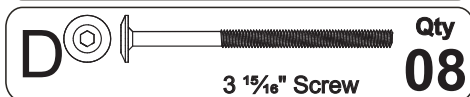
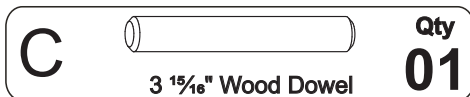
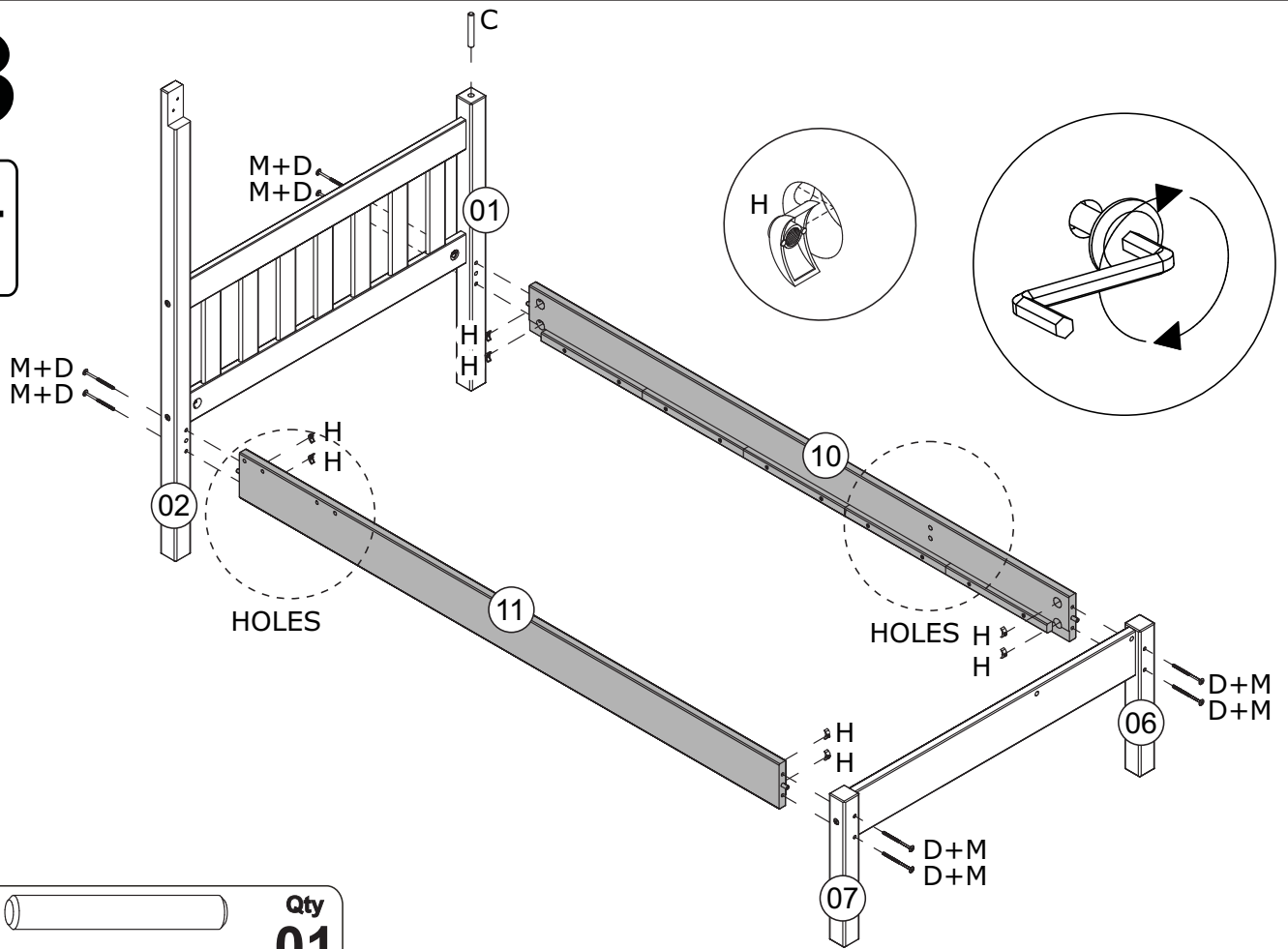

04

LEFT BOTTOM BED

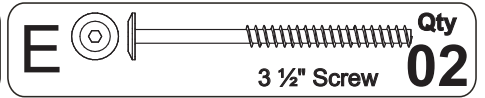
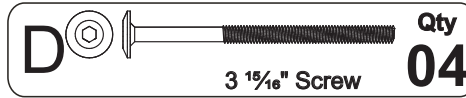
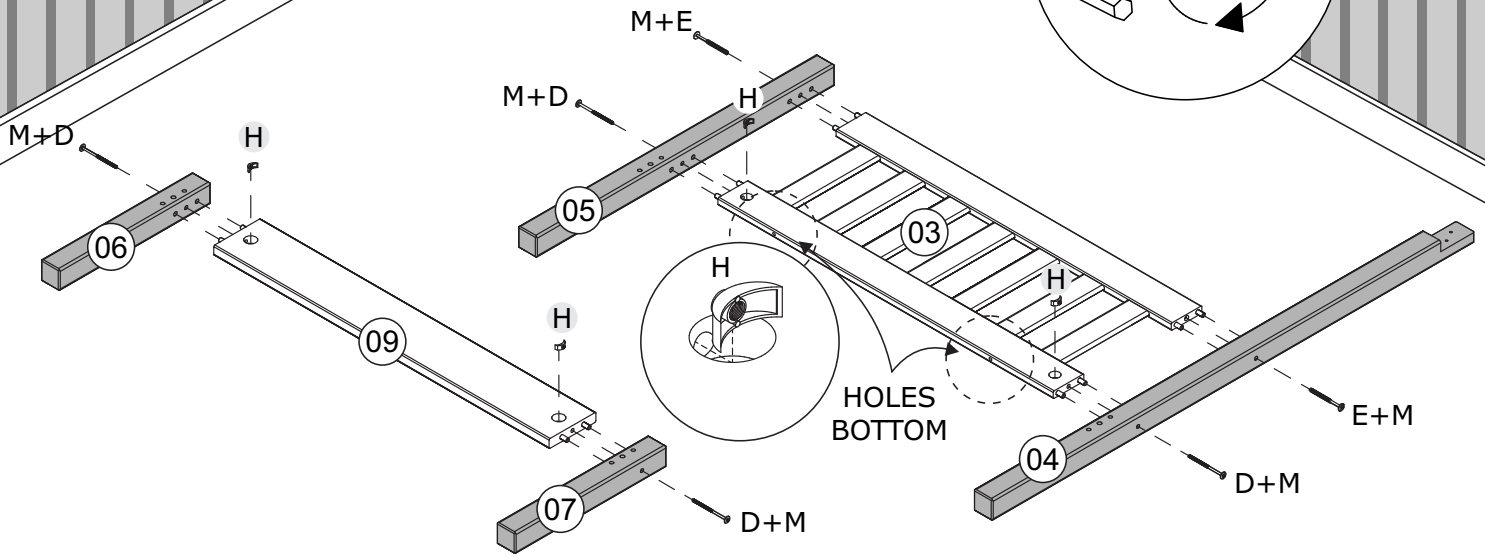

05

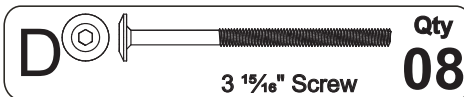
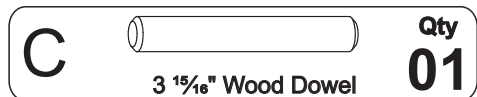
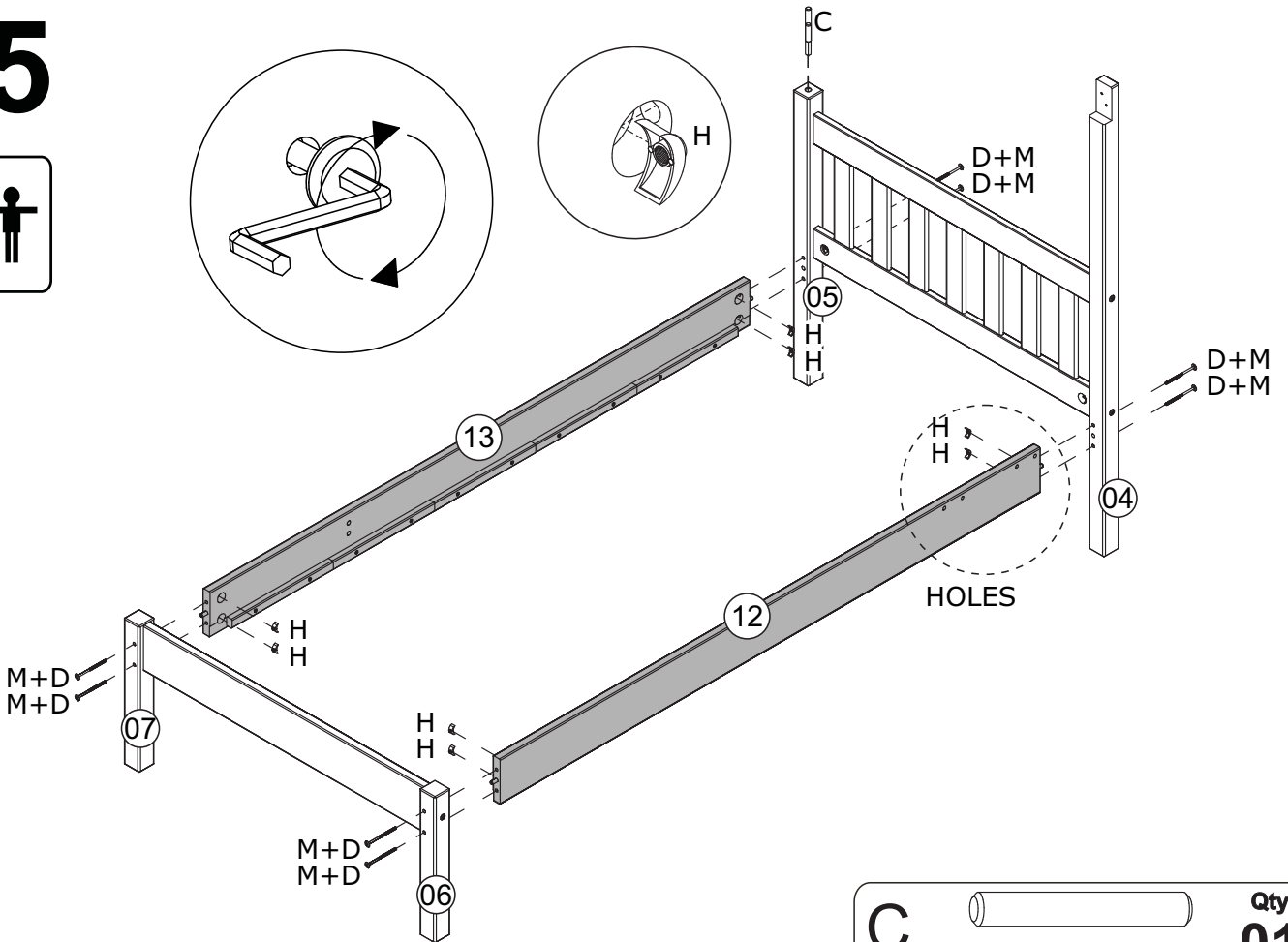
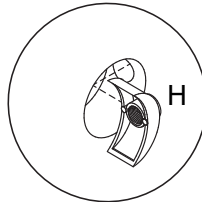
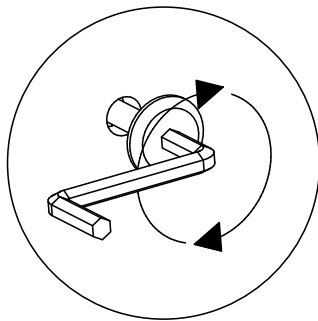

06

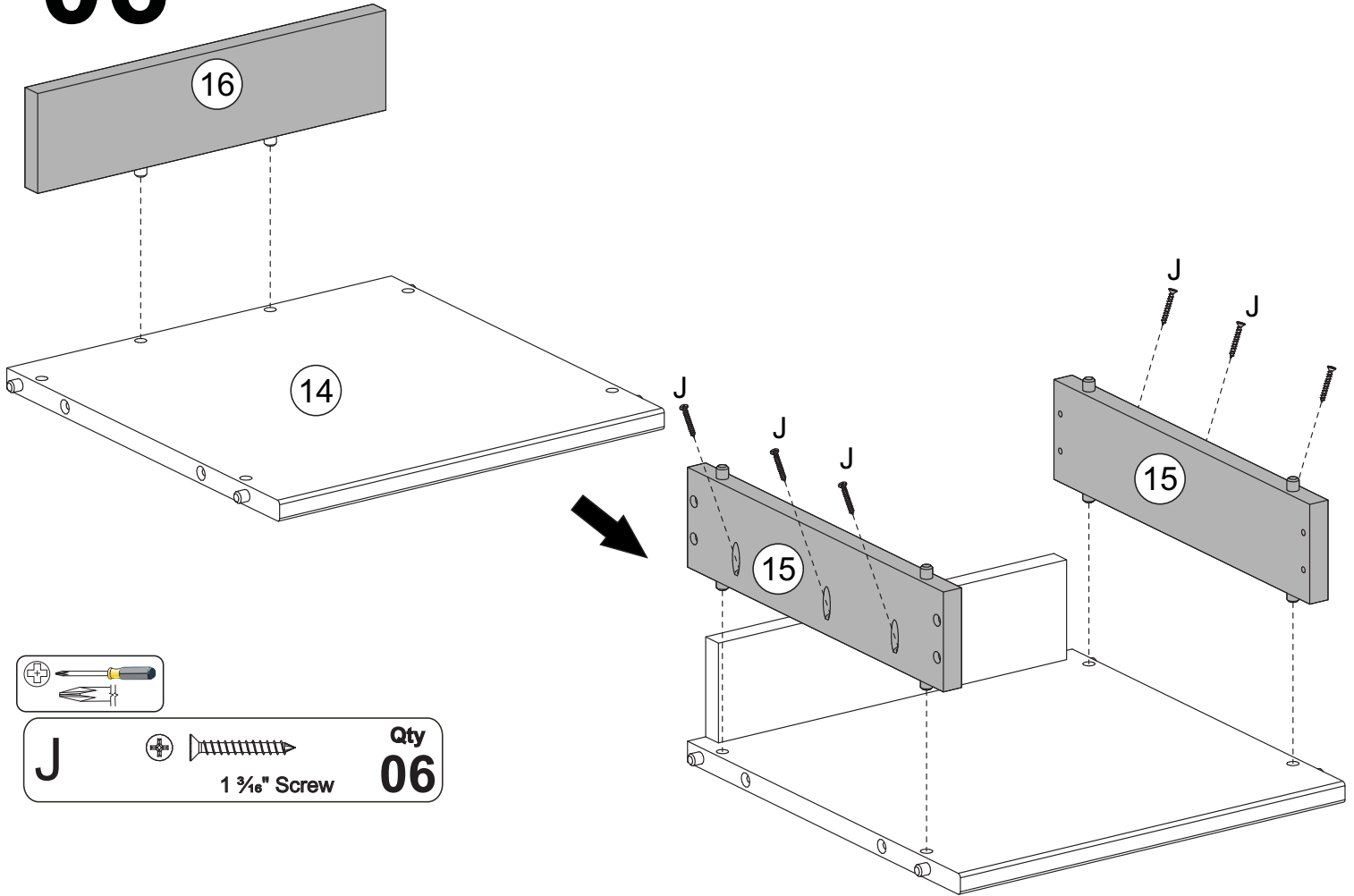

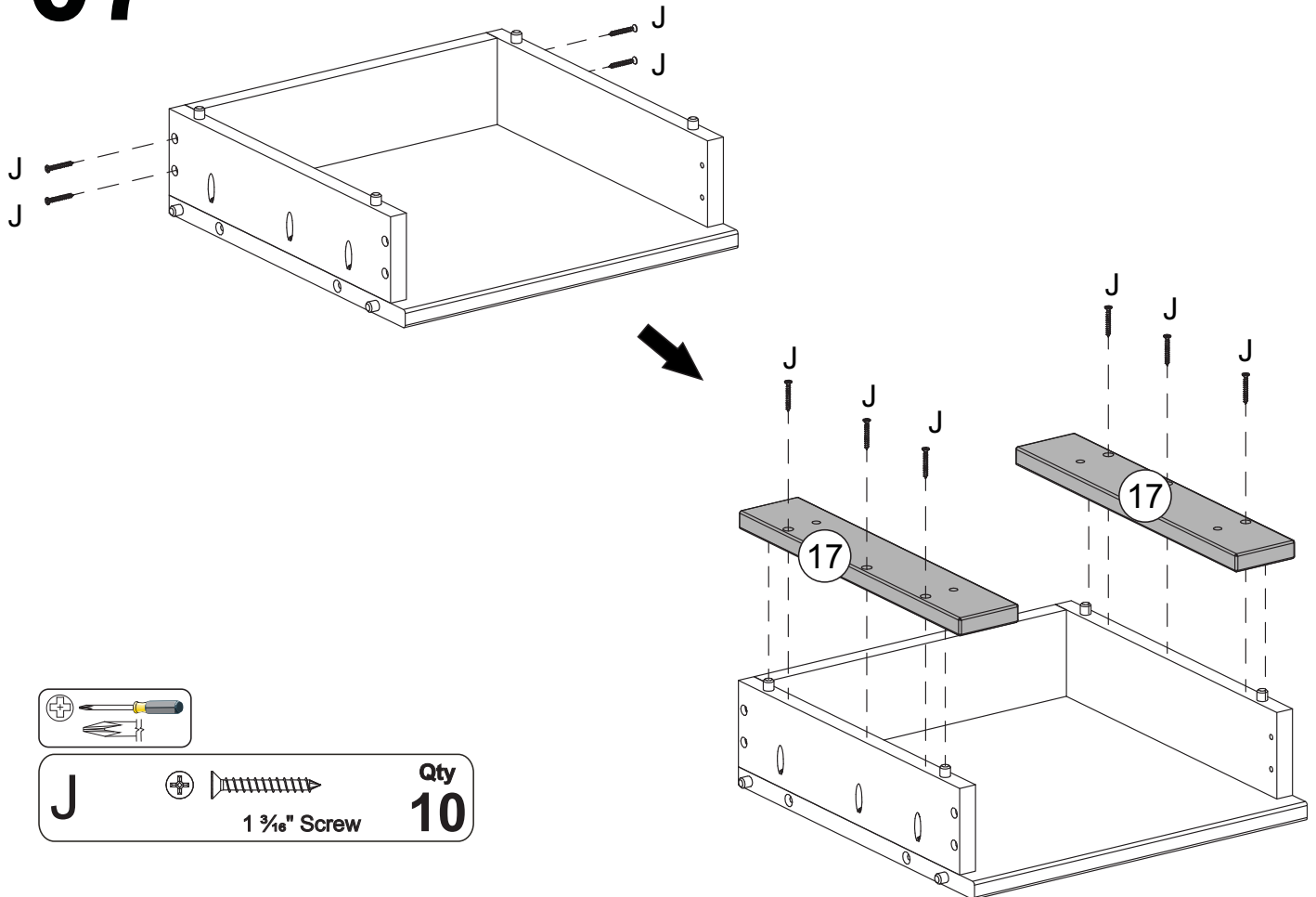

07



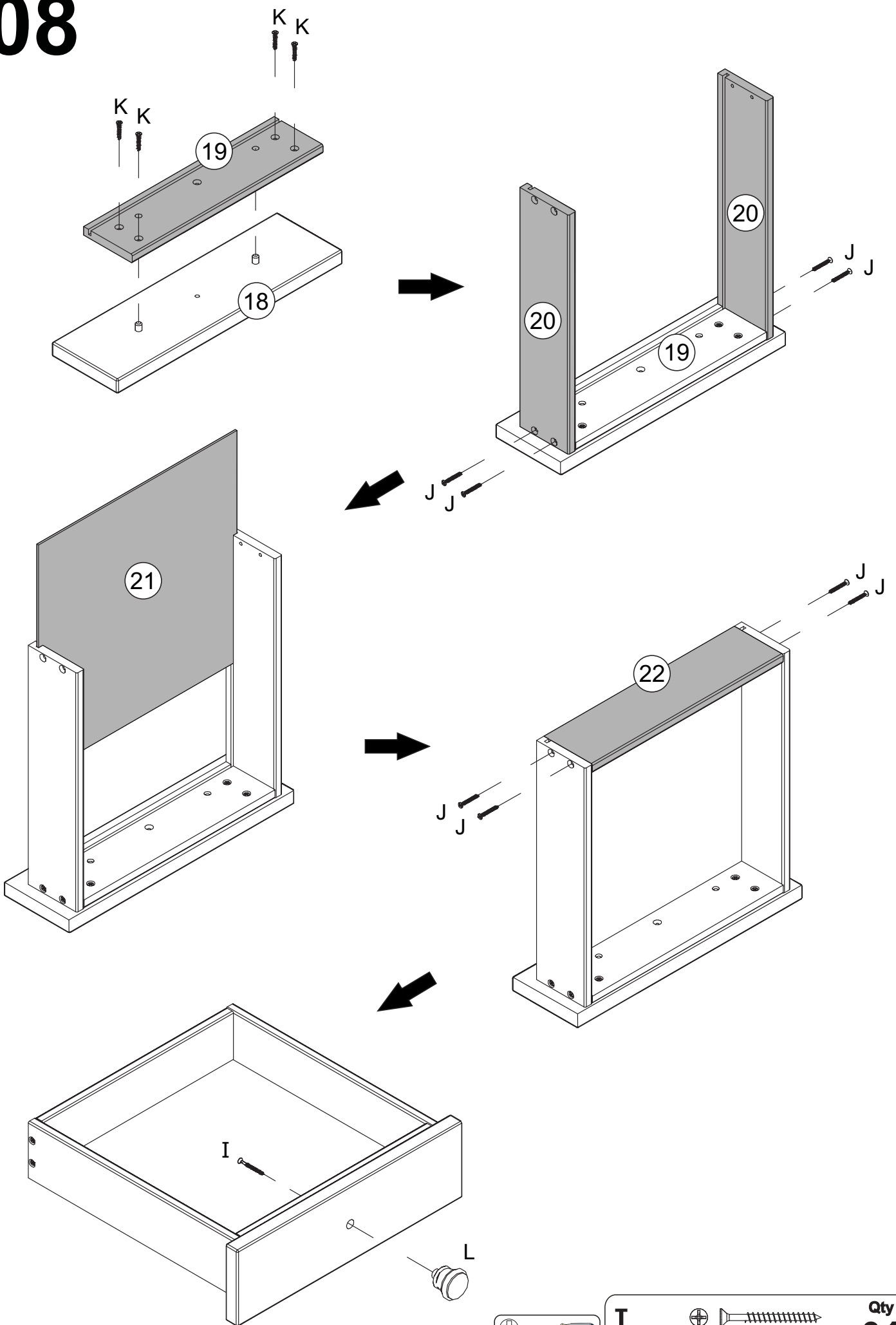

08

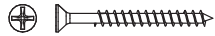

J  Qty **08**
1 3/16" Screw

K  Qty **04**
1" Screw

I  Qty **01**
1 3/16" Screw

L  Qty **01**
Knob

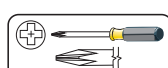

09

FLIP
180°

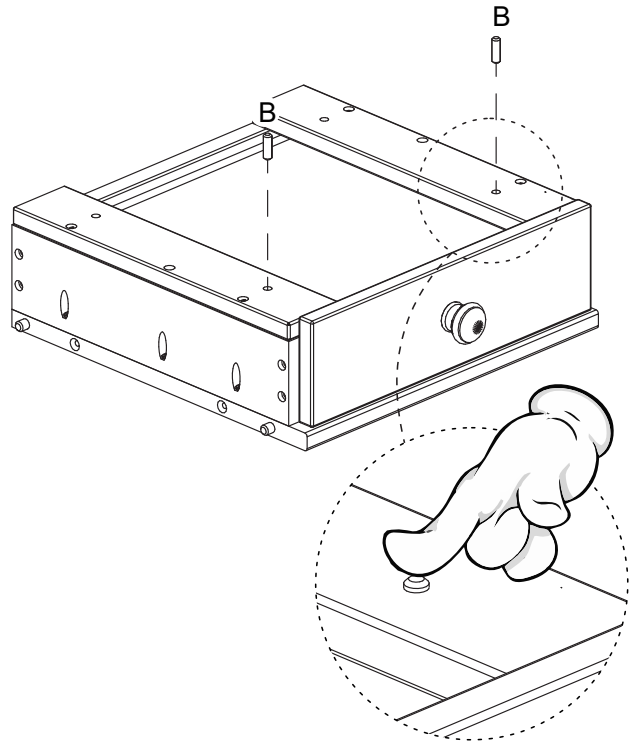
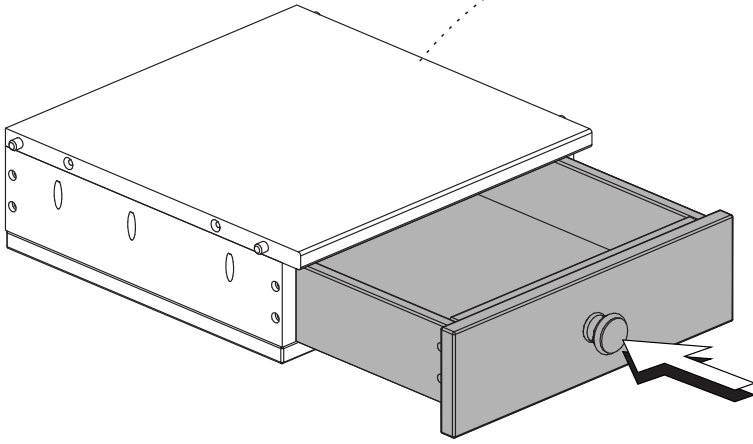

B



1" Wood Dowel

Qty

02

10

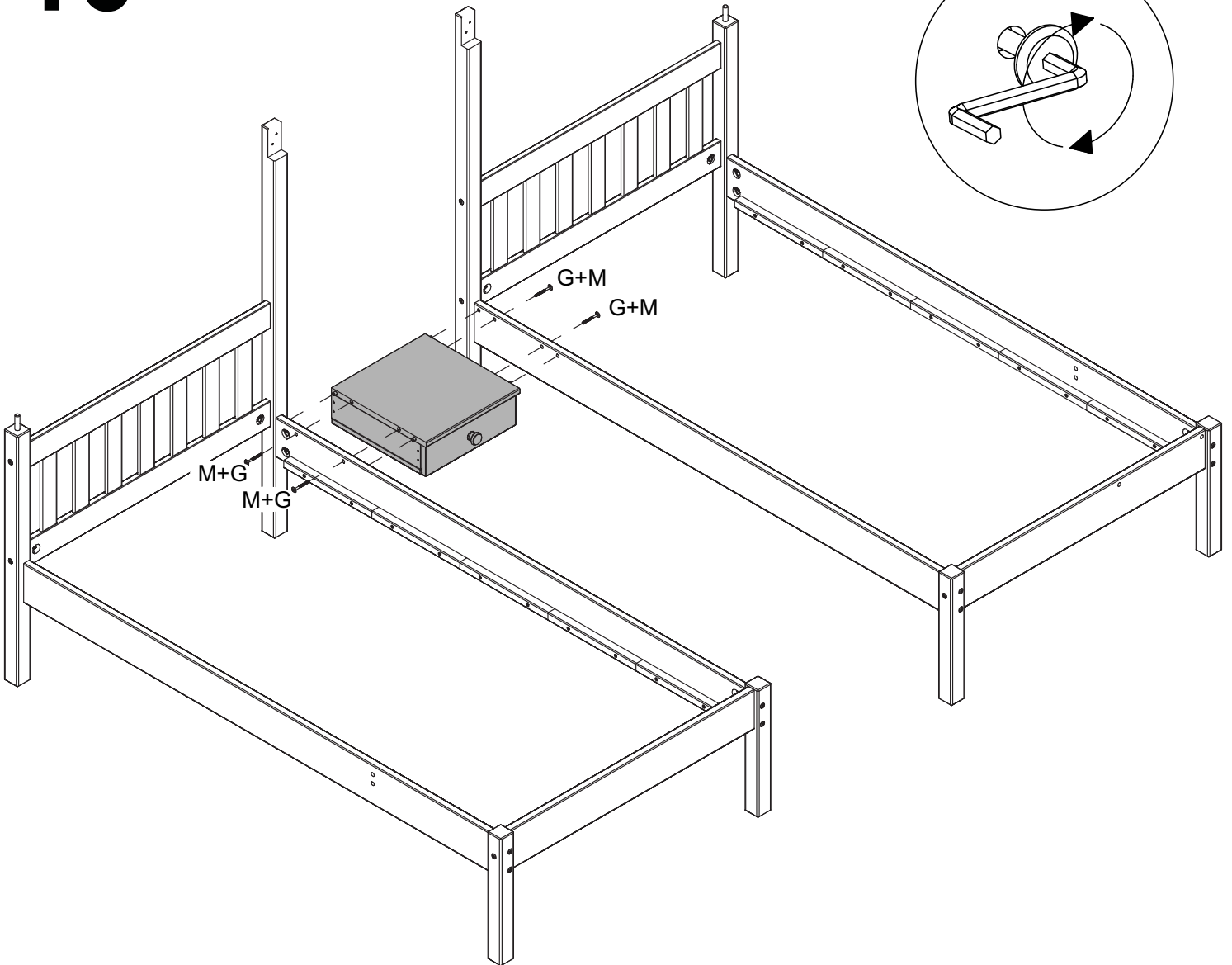

G

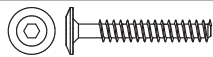

2" Screw

Qty
04

M

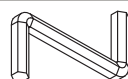

Hex
Screwdriver

Qty
01

11

TOP BED

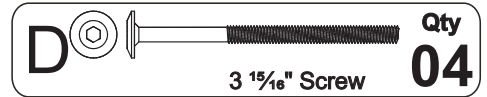
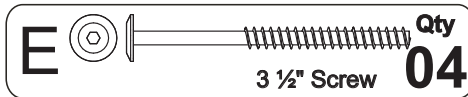
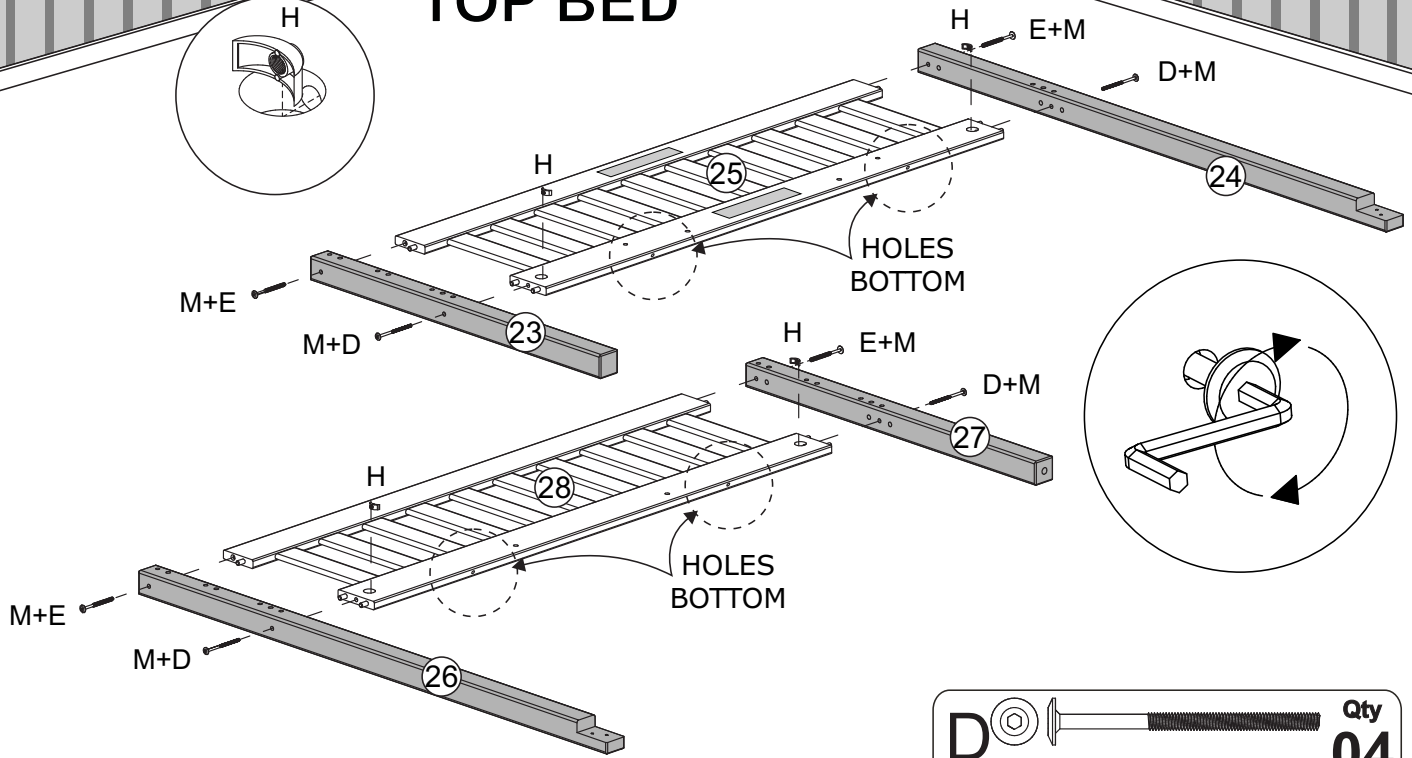

12



Please be careful when assembling this step due to the parts being extremely heavy. Is necessary 2 people on this step

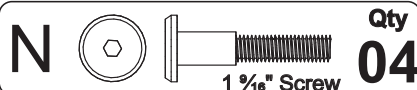
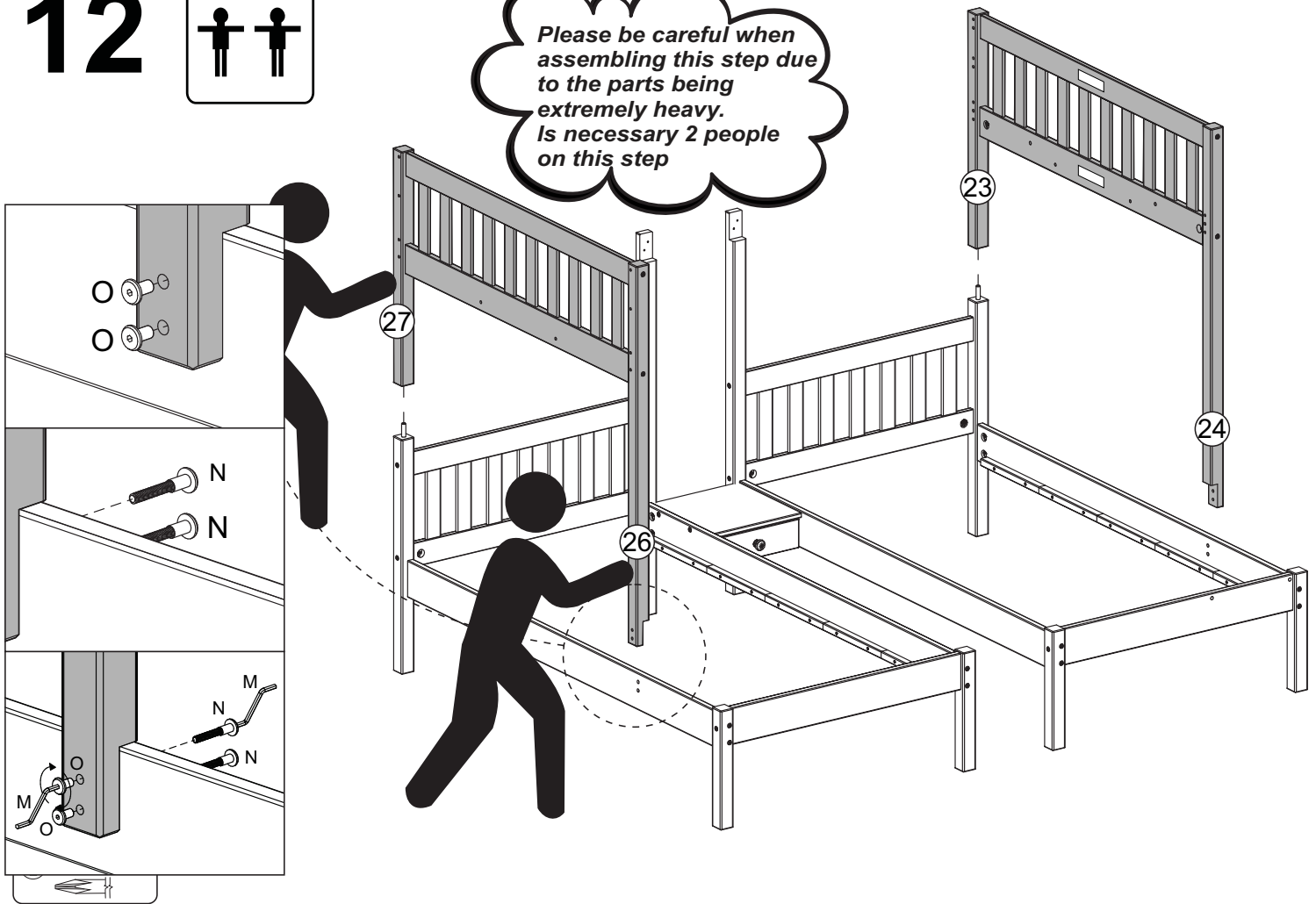

15

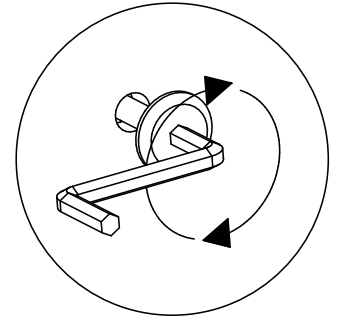
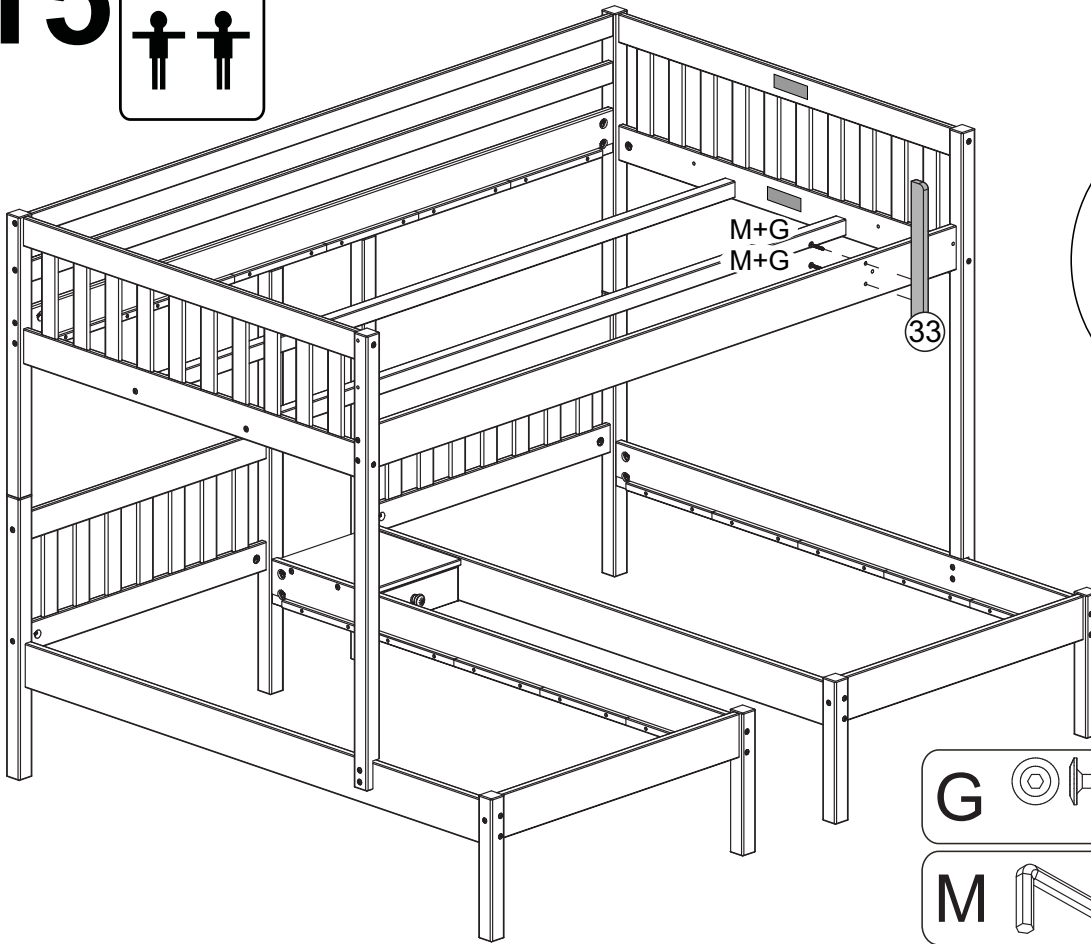

G		2" Screw	Qty 02
M		Hex Screwdriver	Qty 01

16

LADDER

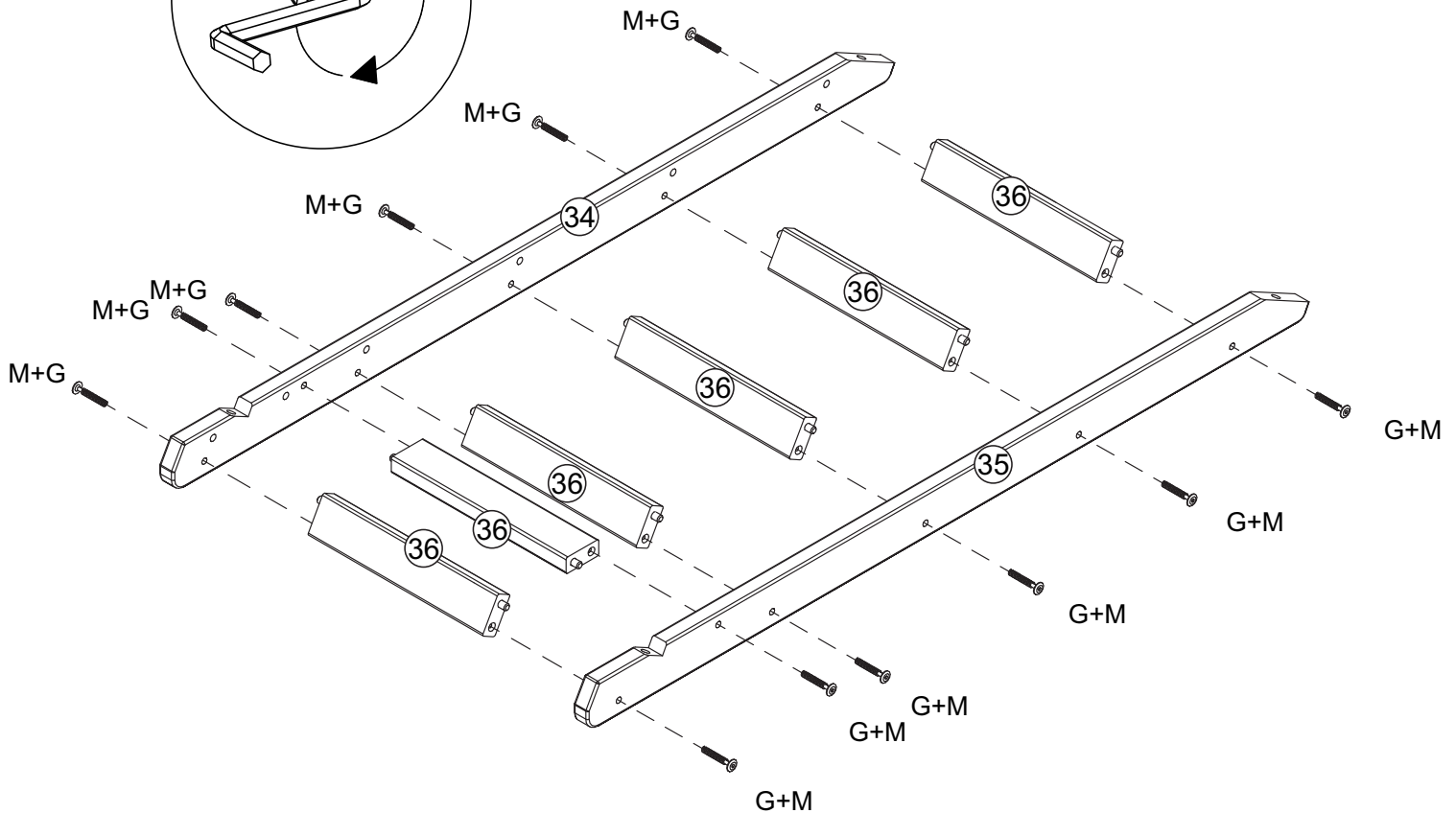
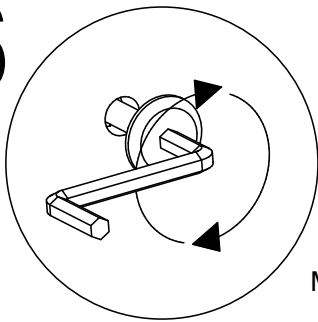

G		2" Screw	Qty 12	M		Hex Screwdriver	Qty 01
----------	--	----------	------------------	----------	--	--------------------	------------------

17

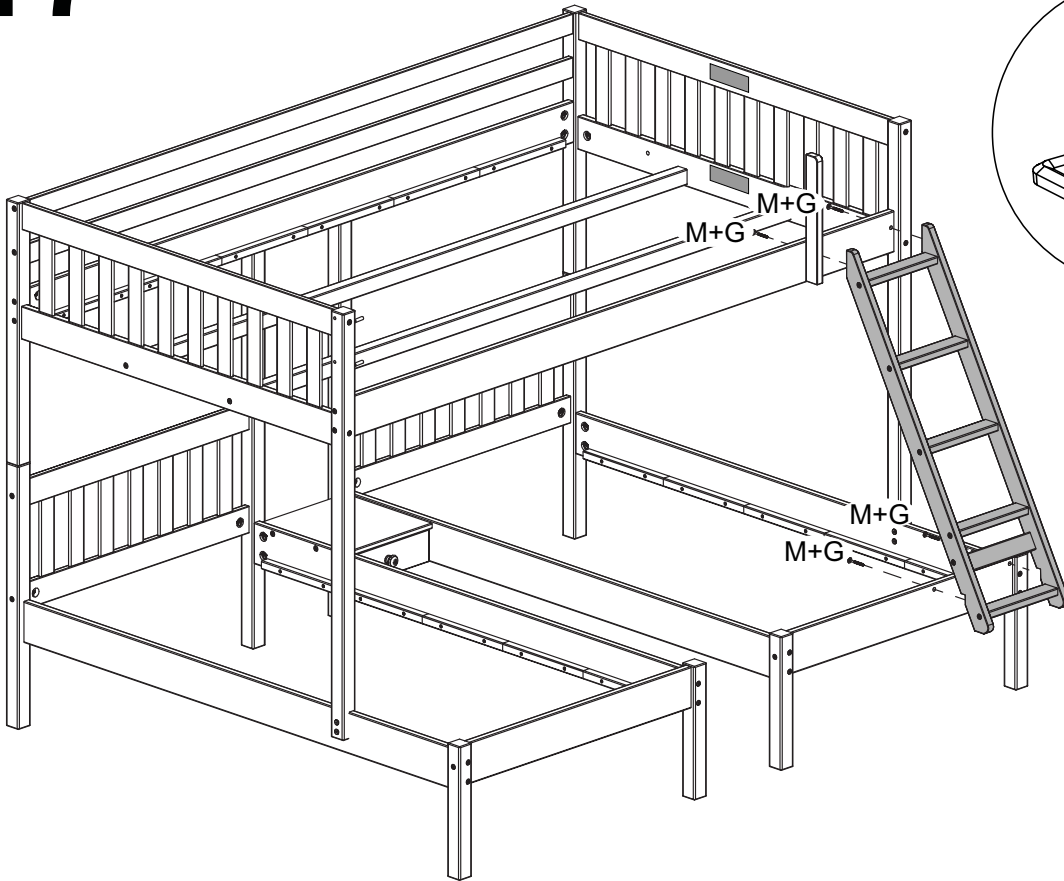



G  **Qty 04** **2" Screw**

M  **Hex Screwdriver Qty 01**

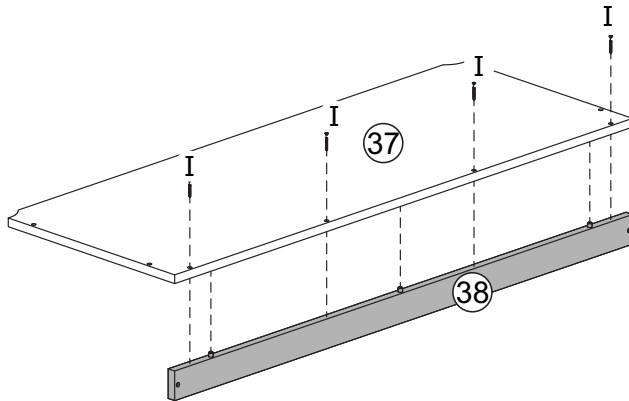
18

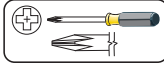



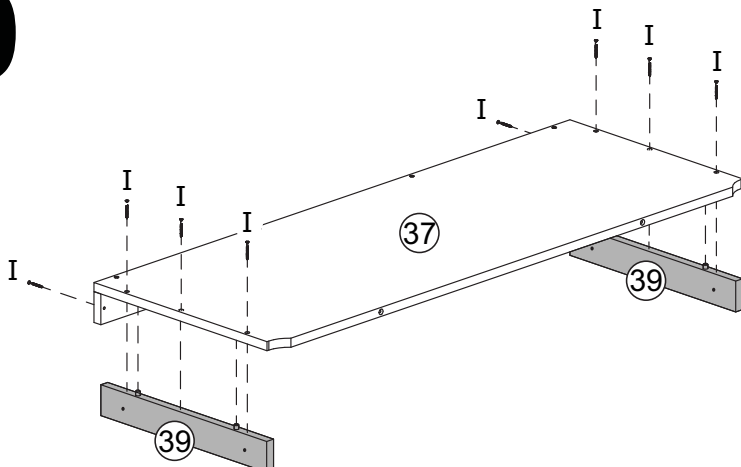

I  **Qty 04** **1 5/16" Screw**

19

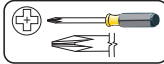



I  **Qty 08** **1 5/16" Screw**

20

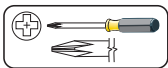
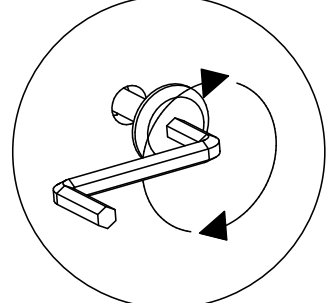
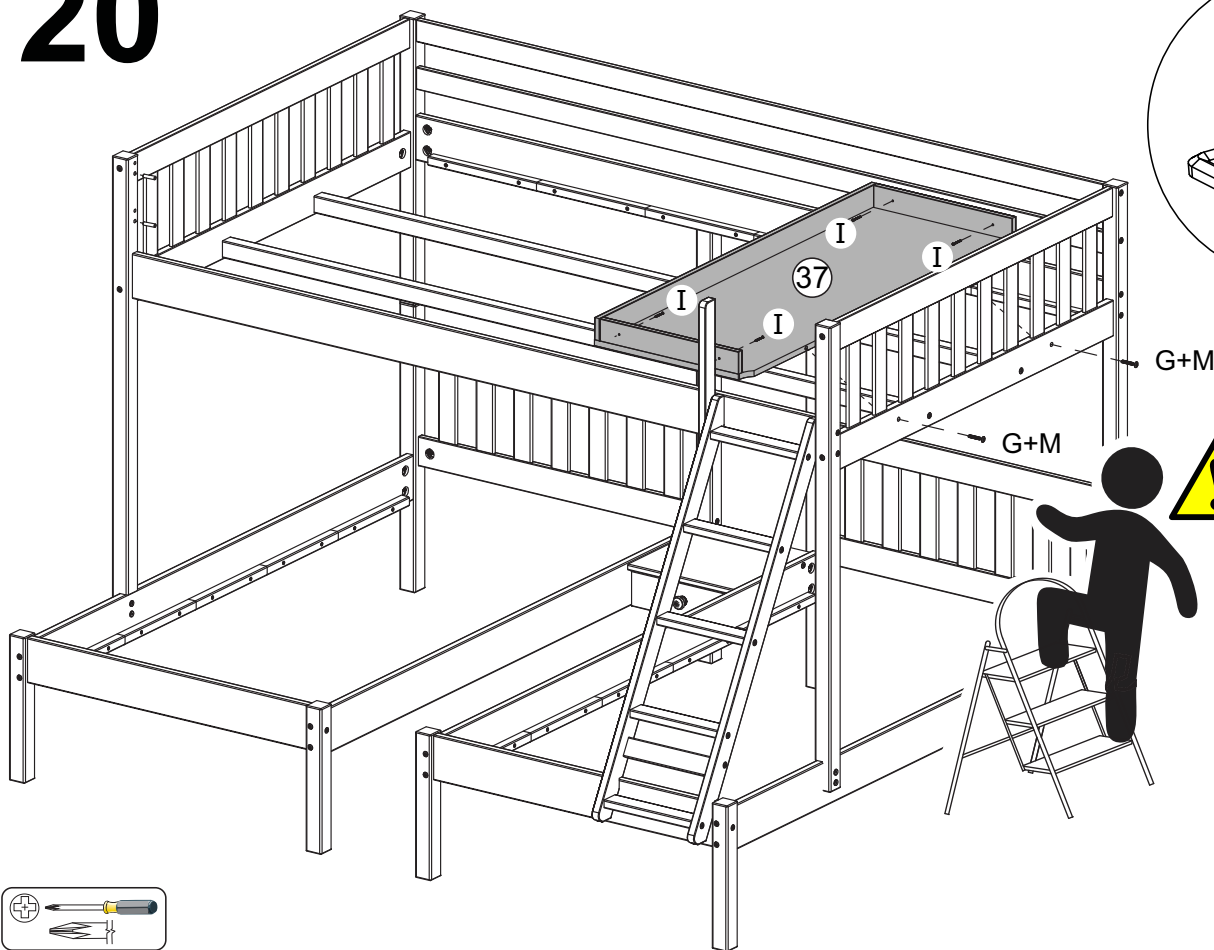

- | | | | | | | | | |
|----------|---------------|---------------|----------|----------|---------------|----------|-----------------|---------------|
| I | | Qty 04 | G | | Qty 02 | M | | Qty 01 |
| | 1 3/16" Screw | | | 2" Screw | | | Hex Screwdriver | |

21

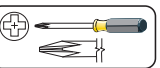
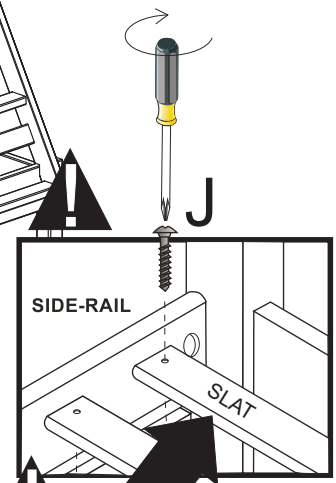
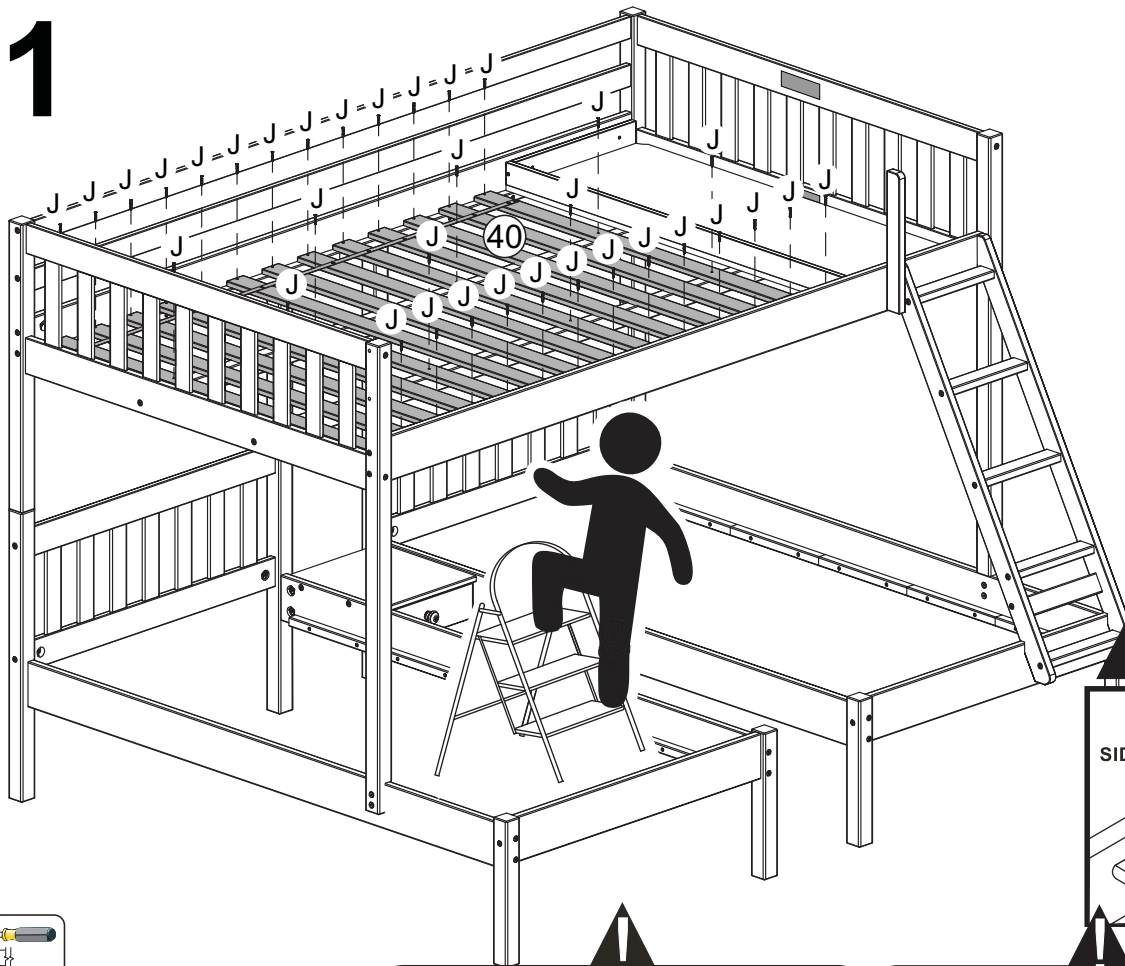

- | | | | | | | |
|----------|---------------|---------------|--|--|---|--|
| J | | Qty 34 | INSTALL SLAT KIT WITH SPACER TAPE ON TOP(FACING UP) | | The first slats must be fixed at 3" from each headboard end. | |
| | 1 3/16" Screw | | | | | |

22

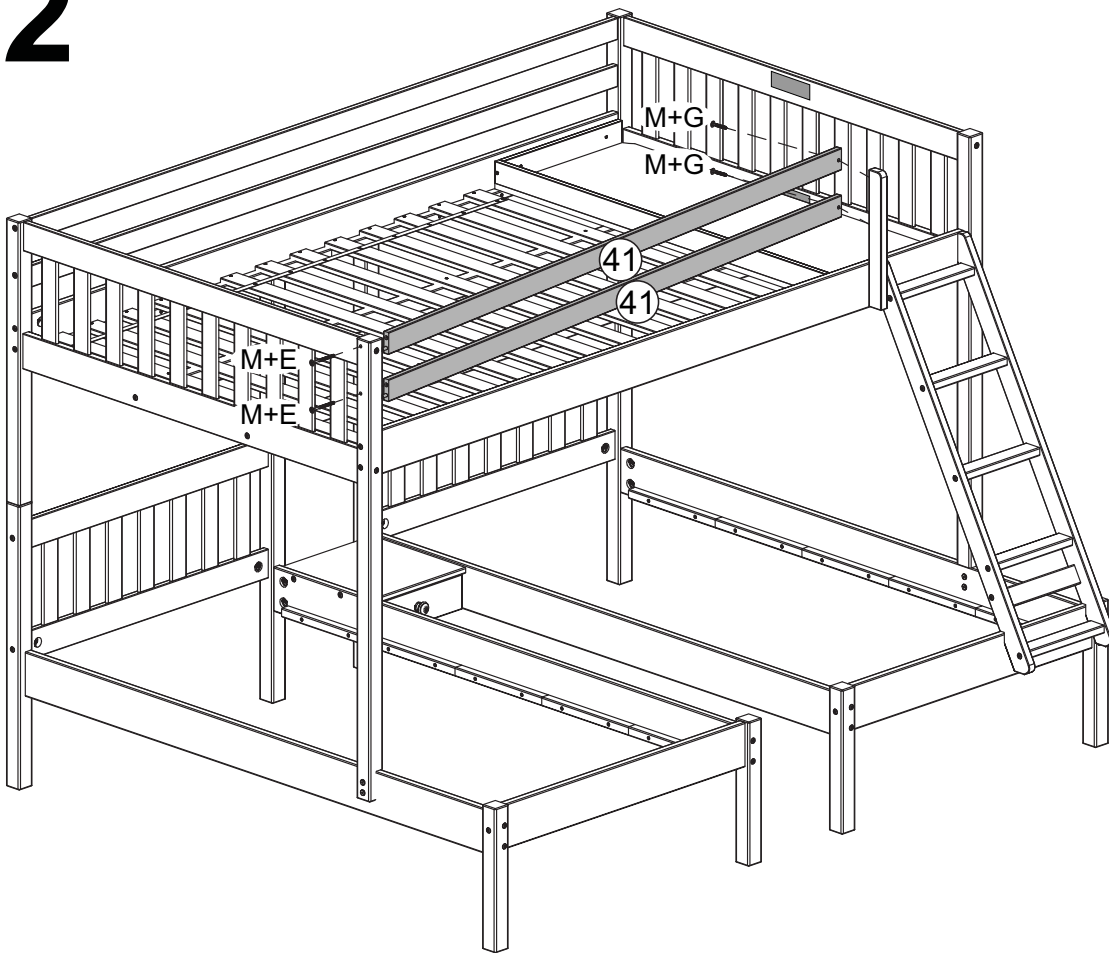

E  Qty **02**
3 1/2" Screw

G  Qty **02**
2" Screw

M  Hex Screwdriver Qty **01**

23

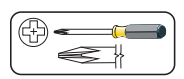
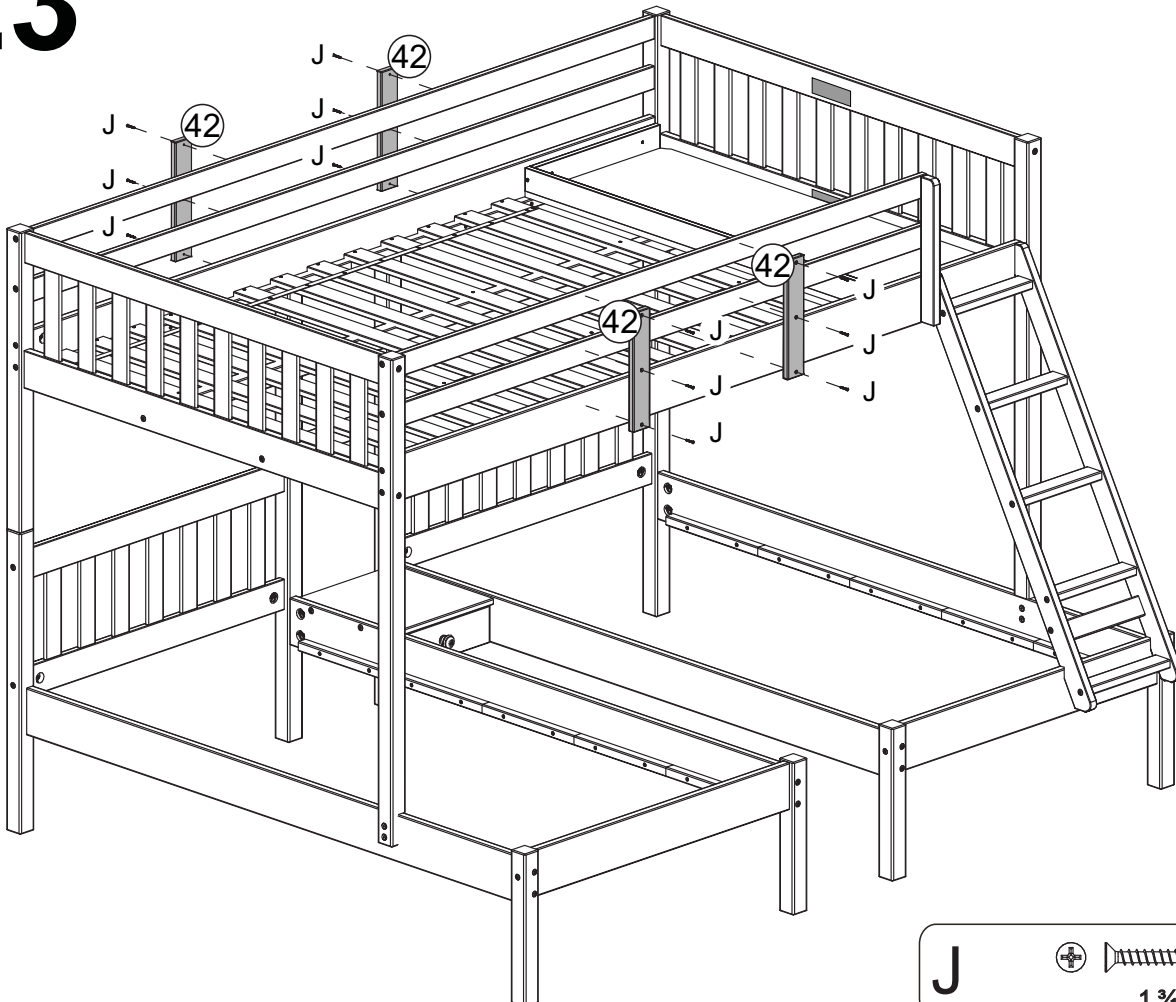

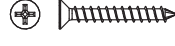
J  Qty **12**
1 3/8" Screw

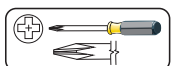
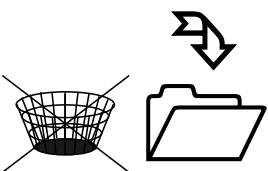
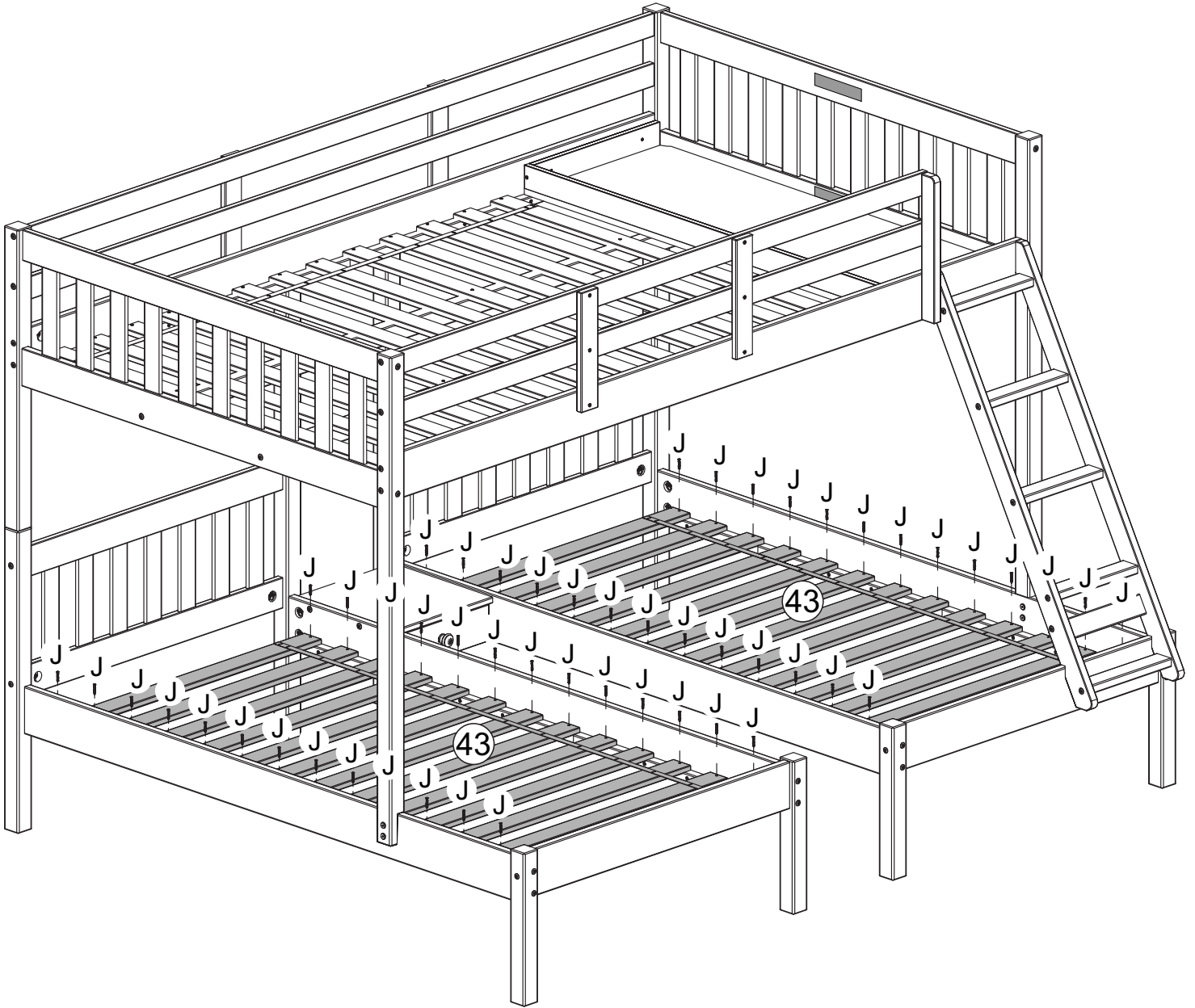

J



1 3/16" Screw

Qty

52